

Coherent FieldMaster GS
Laser Power and Energy Meter



© Artisan Technology Group

\$1595.00

In Stock

Qty Available: 10+

Used and in Excellent Condition

Open Web Page

<https://www.artisanTG.com/50338-1>



Your **definitive** source
for quality pre-owned
equipment.

Artisan Technology Group

(217) 352-9330 | sales@artisanTG.com | artisanTG.com

All trademarks, brandnames, and brands appearing herein are the property of their respective owners.

- Critical and expedited services
- In stock / Ready-to-ship
- We buy your excess, underutilized, and idle equipment
- Full-service, independent repair center

Artisan Scientific Corporation dba Artisan Technology Group is not an affiliate, representative, or authorized distributor for any manufacturer listed herein.

FieldMaster™ GS

Power/Energy Analyzer User Manual



 **COHERENT®**

FieldMaster GS

FieldMaster™ GS Power/Energy Analyzer

User Manual
Software Version 2.10



FieldMaster GS

FieldMaster GS

Contents

General Description	1
Features	2
Unpacking	4
Controls & Connections	5
Front Panel	5
Side Panel	6
Setup	7
Turn On	7
Screens	8
Over Temperature	8
Screens: Menu	9
Invert Display	9
Backlight	9
Contrast	9
Auto Off	10
Alog Out	10
TermChar	10
System Status	10
Home Screen - Quadrant Thermal Detector Head CW	11
Offset	12
Setup	12
Align	13
Energy (Quadrant Thermal Detector Single Pulse Operation)	18
Home Screen - Non-Quadrant Detector Head CW	20
Offset	20
Setup	20
Home Screen - Pulse Detector	21
Clear	22
Auto	22
Range	23
Setup	23
Screens: Tune	24
Reset	25
Auto	25
Range	26
Trend Screen	26
Setup	27
Scroll	29

FieldMaster GS

Contents

Start	30
Remote Control	37
Introduction	37
Making the Software Connection	37
Message Exchange Protocol	37
Data Connections	38
Remote Control Language Syntax	39
Commands and Command Parameters	39
Query Commands	40
Case Sensitivity	40
Program Messages	40
Remote Control Commands	41
Remote Control Error Codes	42
Command Errors	42
Remote Control Screen Display	43
System Configuration Commands	43
System Configuration Queries	45
Data Collection Commands	47
Data Collection Queries	50
Simple RS-232 Program Example.....	58
Simple RS-232 Program Example (Cont'd)	59
Simple RS-232 Program Example (Cont'd)	60
Determining Firmware Version	61
Maintenance	61
Trouble Shooting	62
Specifications	63
Appendix A: FieldMaster GS Block Diagram and Circuit Operation	
Appendix B: Help File	
Sales & Service Information	
Warranty	

FieldMaster GS

General Description



Figure 1. FieldMaster™ GS Power/Energy Analyzer

The FieldMaster™ GS is a rugged, compact, microprocessor based power and energy analyzer that interfaces with the full line of Coherent "smart" power and energy detector heads. FieldMaster GS provides a unique combination of an analog meter for laser tuning, a precise digital display, and graphics analysis of power or energy on a high resolution LCD display.

The FieldMaster GS can be used with all lasers commonly manufactured today – CW and pulsed, from the UV to the IR, with rated power from nanowatts to kilowatts – simply by plugging the appropriate detector head into the console.

FieldMaster GS

General Description (cont'd)

Features

Features of the FieldMaster GS are described below.

Pulsed/CW Measurement

The FieldMaster GS supports CW power measurement and Pulse energy measurement. (See Appendix A for a list of heads supported.)

- **Pyroelectric Detectors** – A complete family of energy measurement pyroelectric detectors for single pulse or pulse train from 1.0 μ J to 20 J.
- **Semiconductor and Thermal Detectors** – FieldMaster GS is compatible with semiconductor detectors and the full range of Coherent's patented thermal disk *Smart Detector Heads*, providing power measurement capability from 1 nW to 5 kW.

Versatility

More than just a power/energy meter, the FieldMaster GS also provides complete power and energy trend information, beam position drift measurement, statistics, and tuning.

Communications

The FieldMaster GS supports the following communication modes:

- **Analog Out** – Provides 0-1 Volt output at 5Hz update rate to operate an external device such as a chart recorder.
- **RS-232 Interface** – Standard RS-232 interface for full interactive operation of the FieldMaster GS by a computer. The interface can also be used to download data from the unit to a computer for storage, graphing and analysis.

Hot Detector Head Swapping

The FieldMaster GS allows swapping of detector heads while power remains On. After a swap, the unit reboots with the correct settings for the new detector head.

FieldMaster GS

General Description (cont'd)

Smart Detector Technology

FieldMaster GS detector heads utilize Coherent's *Smart Detector Technology*. Each detector head has an EEPROM which stores the characteristics and calibration data for the detector. This information is read by the FieldMaster console at start-up, eliminating the need to make manual changes to the console when changing detectors. **NOTE:** This does not refer to user required entries for Display Average, Wavelength, and Attenuation.

Analog Sensitivity and Feedback

The analog meter movement in the FieldMaster GS gives fast, smooth feedback and provides the fast response time necessary for laser tuning.

Digital Precision

The FieldMaster GS unique high resolution LCD graphic display provides precise digital readout of power or energy as well as indicators for warning or error conditions and graphic analysis of data collection.

Beam Alignment

Thermal disk CW sensors provide a quadrant display of beam position on the detector head. Centering the beam on the detector head achieves maximum accuracy.

Broad Wavelength Range

FieldMaster detectors cover the spectrum from 0.19 to 10.6 μ meters.

Ease of Use

FieldMaster GS controls on the front panel and the simplified menu structure provide ease of use with minimal training. All adjustments for different detector heads are handled automatically using *Smart Detector Technology*.

Portability

The compact, lightweight console and internal rechargeable battery pack create a system that is easily transported from lab to lab, or around the world.

FieldMaster GS

General Description (cont'd)

Reliability

The FieldMaster GS, with its integral cover, is designed to withstand the rigors of travel and regular field use. Coherent's rugged detector head design has been the industry standard for more than 30 years.

Accuracy

The combination of Smart Detector Technology, laser wavelength entry, and accurate beam positioning information create a highly accurate laser measurement system.

Unpacking

The FieldMaster GS console and detector heads are shipped in foam inserts. Batteries are installed in the console prior to shipment. To insure correct battery operation, the batteries require an initial overnight (16 hours) charging.

Visually check all cartons for damage before unpacking. If there is no visible damage, remove all items from the cartons and inspect for damage. Advise Coherent of any damage immediately. A Returned Material Authorization will be issued for any damaged instruments (see the last page of this manual for Service).

FieldMaster GS

Controls & Connections

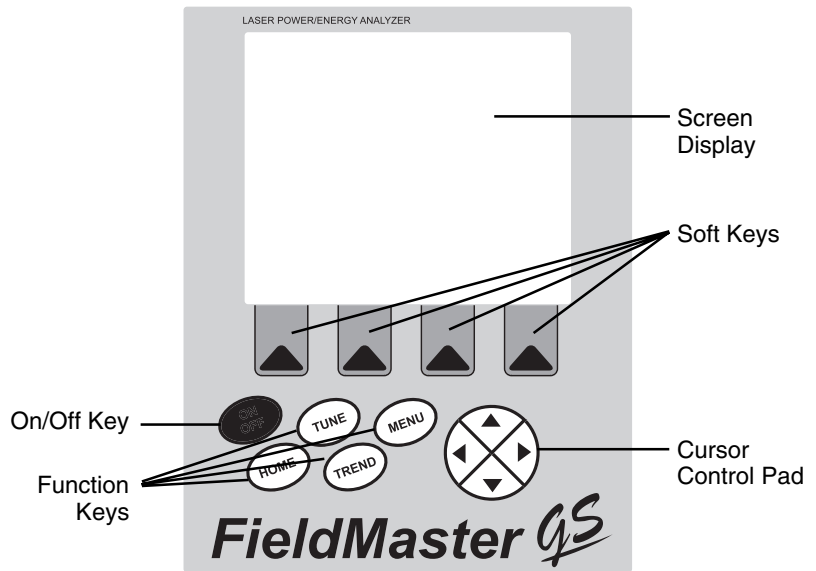

Figure 2. Front Panel Controls

Front Panel

In addition to the LCD graphics screen, all controls for the FieldMaster GS are on the front panel (see Figure 2). Controls consist of:

- **Soft Keys** – The four soft keys, shaped like arrow heads, are immediately under the display screen. Use these keys to select, set, and change various operating functions displayed on the screen.
- **Function Keys** – Use these oval keys to select one of the four main display and analysis screens. These are "hot" keys (i.e., always active).
- **ON/OFF** – Use this oval key to turn FieldMaster GS power On and Off.
- **Cursor Control Pad** – This circle with a small arrow head in each quadrant controls the movement of the cursor on a display. Use the up and down arrows to select the next or previous item (highlighted); the left and right arrows to move left and right on highlighted digits within a highlighted item. The cursor wraps up or down within a list, and left or right within a set of digits.

FieldMaster GS

Controls & Connections (cont'd)

Side Panel

The side panel of the FieldMaster GS console (see Figure 3) has a female DB25 type connector, a female DB9 type connector, an RCA connector, and the power connector.

Connect the detector to the DB25 connector. The FieldMaster GS is designed for use with only Coherent's *Smart Detector Heads*. Do not plug other types of detectors into the FieldMaster GS console.

If using a computer for remote control and data transfers, connect it to the DB9 connector (RS-232 interface).

To drive an external device such as a strip chart printer, connect it to the RCA connector which provides a 0 to 1V analog output. (An RCA-to-BNC adapter is stored in the battery compartment.)

Connect the power supply provided with the FieldMaster GS for regulated 9VDC 0.4A power. **Use only the provided Coherent power supply.**

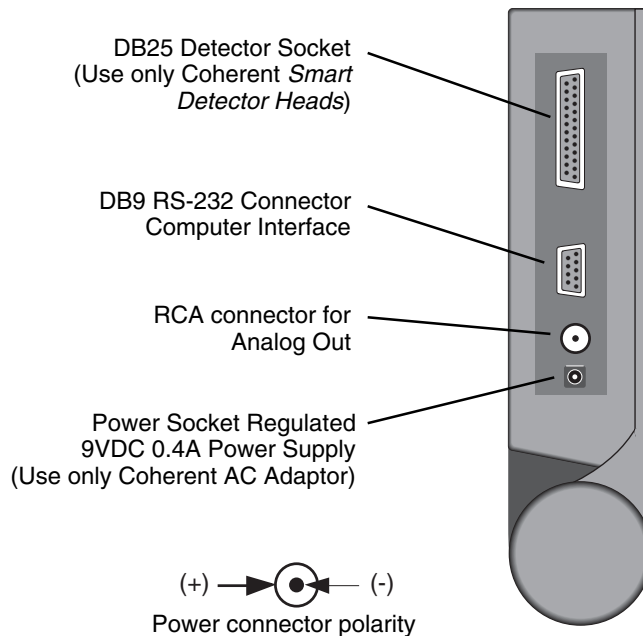

Figure 3. Side Panel Connectors

FieldMaster GS

Setup

The front cover of the FieldMaster also serves as the stand for the unit. Rotate the cover down around the back of the unit and place on a convenient surface.

The FieldMaster GS may be powered by using the provided AC Adapter or by using the factory installed rechargeable batteries. If using the AC Adaptor, plug it into a 110 VAC outlet (in Europe, 220 VAC) and connect it to the AC Adapter connector on the left side of the FieldMaster GS (see Figure 3).

If using battery power, The Home, Tune and Trend screens provide a **LOW BATTERY WARNING** indication when there is 10% of battery life remaining. Plug the unit into an AC outlet to recharge the batteries.

Plug the detector head into the DB25 connector on the left side of the console. The unit is now ready to turn power on.

CAUTION: Insure that your detector head is rated for the power or energy density of your laser. Power or energy density greater than the rating of the sensor will damage the detector head.

Turn On

Press the On/Off key on the front panel. The unit beeps once and the screen displays the System Status of the FieldMaster GS for approximately 5 seconds.

A query is sent to the EEPROM in the detector head. If no detector head is plugged in or either the detector head or detector cable is defective, the message NO DETECTOR will be displayed on the System Status screen, and the unit will beep continuously every 10 seconds.

When the self tests are completed and the parameters for the detector have been loaded, the Home screen appears.

Screens

Operation and use of the FieldMaster GS is through the various display and analysis screens and the ability they provide to setup and control the system. There are four primary screens which correspond to the front panel function keys. The Menu screen provides basic, system wide control functions.

The information displayed on the Home screen is detector head dependent. The other two analysis screens - Tune and Trend - provide controls which are consistent across all detector heads.

Over Temperature

If the temperature at the detector head sensor exceeds the maximum operating temperature at any time, the screen will go blank and then **OVER TEMP** will appear in the middle of the screen. After 5 seconds, the unit reads the sensor temperature again. If the temperature is still over limit, **OVER TEMP** returns. If the temperature is within limits, normal operation resumes.

Screens: Menu

Menu Screen

Press the MENU Function key to display the Menu screen shown in Figure 4. When this screen appears, the top item is highlighted to indicate it is the current selection. Items on the Menu screen are described below. In this screen:

Press ENTER to enable any changes made and return to the Home screen.

Press ESCAPE to negate any changes and return to the Home screen.

On the Cursor Control pad, press the up and down arrows to select the next or previous item (highlighted); press the left and right arrows to move left and right on highlighted digits within a highlighted item. The cursor wraps up or down within a list, and left or right within a set of digits.

Screens: Menu (cont'd)



Figure 4. MENU Screen

Invert Display

Use this item with the INC/ON and DEC/OFF soft keys to turn the reverse display mode On or Off. This is a personal preference parameter. Default mode is Off with black text on a white background. Note that this setting is retained in nonvolatile memory during On/Off cycles and regardless of the detector connected.

Backlight

Use this item with the INC/ON and DEC/OFF soft keys to turn the backlight Off and On. Default mode is On and recommended for normal use, and under low ambient light conditions. In this mode, battery power will last approximately 4 hours. Note that this setting is retained in nonvolatile memory during On/Off cycles and regardless of the detector connected.

Contrast

Use this item with the INC/ON and DEC/OFF soft keys to increase or decrease the contrast from 0 (dark) to 100 (light). Default setting is 50. Note that this setting is retained in nonvolatile memory during On/Off cycles and regardless of the detector connected.

Screens: Menu (cont'd)

Auto Off

Use this item with the INC/ON and DEC/OFF soft keys to change the time in minutes that the unit will stay on between key presses before automatically turning off. Default setting is 0 with the maximum being 480. The Auto Off mode is disabled if set to 0. This feature is only functional when using battery power.

Alog Out

Use this item with the INC/ON and DEC/OFF soft keys to adjust the full scale power/energy range at the Analog Out side panel connector. This output, equivalent to 1VDC, is from a 12-bit D/A which provides an output impedance of 1.5K ohms. No other screen functions will change this range. This setting, retained in nonvolatile memory during On/Off cycles, reverts to default if a different detector is plugged in.

NOTES: Analog out is not active in trend mode if data is not being collected. In pulse mode, clear or reset keys do not clear the value on the analog out.

TermChar

Use this item with the INC/ON and DEC/OFF soft keys to set the RS-232 communication termination character the FieldMaster GS and host computer use. Pressing INC/ON or DEC/OFF scrolls through the four choices of termination characters listed below. The computer communication software determines which termination character must be used.

\ - back slash

CR - carriage return

LF - line feed

CR-LF - carriage return and line feed

System Status

Use this item to display the System Status screen (Figure 5). (This is the same screen which briefly appears when the unit is turned on.) The System Status screen identifies the detector head connected to the unit and the software version installed in the unit. Press EXIT to return to the main menu. Note that **No Detector** appears in the lower portion of this screen if a detector is not connected or either the detector head or cable is defective.

FieldMaster GS

Screens: Menu (cont'd)

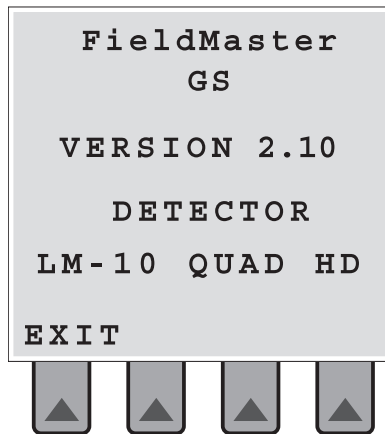

Figure 5. System Status

Screens: Quadrant Home

Home Screen - Quadrant Thermal Detector Head CW

The Home screen which appears when using a Quadrant CW Detector Head is shown in Figure 6. This screen displays either the default parameters or the current operating parameters for: Display Average; Wavelength; Attenuation; and Offset. From this screen, use the soft keys to select Offset, Align, Energy, and Setup. The Offset and Setup functions are displayed on the Home screen while the Align and Energy functions are displayed on additional screens.

A target showing the location of the beam on the detector is on the right side of the display. For maximum accuracy, align the detector so that the beam location indicator is within the small circle of the target.

Screens: Quadrant Home

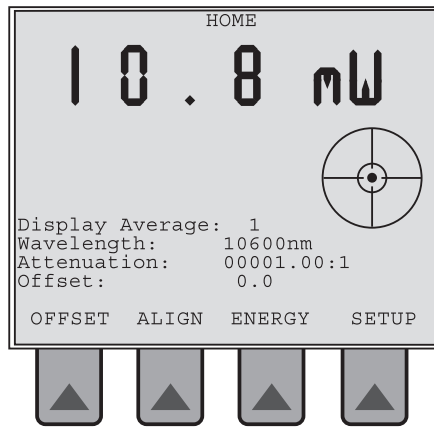

Figure 6. Home - Quadrant Thermal Detector Head CW

Offset

Press the OFFSET soft key to use the current power reading as an offset value (zero reference) to eliminate a constant background reading. When first pressed, the screen displays zero and the offset value is shown at the bottom of the screen. The second time the key is pressed, the offset value is returned to zero regardless of the power input at the time the key is pressed and the screen displays 0 offset.

Setup

Use the SETUP soft key to change the parameters for Display Average, Wavelength and Attenuation. When pressed, Display Average is highlighted (selected). Use the up and down cursor control keys to select parameters and the INC/DEC keys to change values of the highlighted parameter.

Display Average - Enter the number of readings to be averaged for the displayed power or energy value. Valid entries are 1, 2, 5, 10, 20, 50, 100, and 200. Measurements are calculated at 10 Hz (i.e., 10 per second). The display is updated at 3 Hz with the value of the most recent average. The Display Average is the number of 10 Hz measurements to be used in the average using the running average method. The display itself is still updated at 3 Hz. NOTE: Display averaging affects the Trend function. It does not affect the Tune function.

Screens: Quadrant CW Align

Wavelength - Enter the wavelength of the laser measured. Use the left and right cursor control keys to move within the digits. **NOTE: This entry must be exact to insure accuracy.**

Attenuation - Enter the amount of optical attenuation due to beam splitters, attenuators, or other optical elements. Use the left and right cursor control keys to move within the digits. (Attenuation affects the tune, trend and analog out.)

Press ENTER to accept the changes and return to the Home screen. As long as the same detector is connected, the values entered here are saved during On/Off cycles. If a different detector is installed, default values will be used until changed. To negate any changes and return to the Home screen, press ESCAPE.

Align

When Align soft key is first pressed from the Home screen, the soft keys change to ALIGN, POSITION, AND CANCEL. Press Cancel to return to the Home screen. Align and Position soft keys are discussed below.

Align Screen - The Align screen, shown in Figure 7, displays the position of the beam on the detector and allows use of quadrant thermal detector heads for optical system alignment. The displayed target at 1X resolution represents the clear aperture of the detector with aperture size shown in mm just below the target.

Use the REL soft key to toggle the representation between Absolute and Relative modes. The Absolute mode shows the actual position of the beam on the detector and the Relative mode shows the initial position of the beam at the center of the target (see examples below). The current mode, Rel or Abs, appears to the right of the diameter value. Default mode is Absolute.

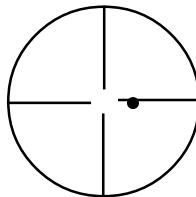

Abs

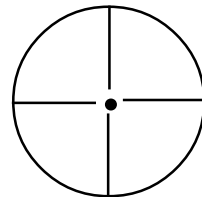

Rel

Screens: Quadrant CW Align (cont'd)



Figure 7. Alignment - Quadrant Thermal Detector Head CW

Use the ZOOM IN/OUT soft keys to decrease (Out) or increase (In) the resolution of the target display. Each time a key is pressed, the resolution value changes. Values available are: 1X, 2X, 4X, 8X, 16X, and 32X. For example, press ZOOM IN and observe that the Zoom value changes to 2X and the Absolute/Relative value changes from 19.0 mm to 9.50 mm.

To exit this screen, you must press any Function key.

Press the CALIB soft key to calibrate the positional accuracy of the detector. This key is used to improve accuracy over the stored default values. When pressed, the Calibrate 1 screen appears (see Figure 8). Press RESET to restart the process, or press CANCEL to abort the operation and return to the Align screen, or follow the instructions on the display.

When following the instructions on the display and the beam has been centered, press START. The Calibrate 2 screen as shown in Figure 9 appears.

Press CANCEL to abort the operation and return to the Align screen, or follow the instructions on the display. When following the display instructions, pressing CALIB resets the calibration of the unit so that measurement of the distance moved is exactly 5mm. The calibration factor is stored in nonvolatile memory.

To exit this screen, you must press any Function key.

Screens: Quadrant Calibrate

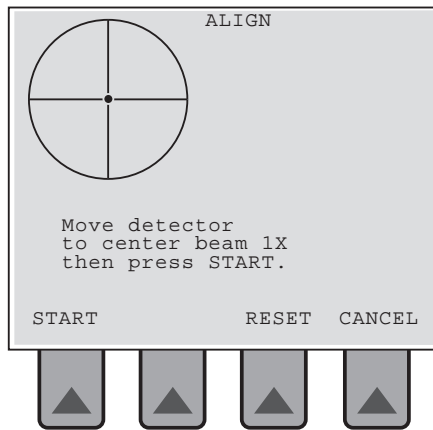

Figure 8. Calibrate 1 - Quadrant Thermal Detector Head CW

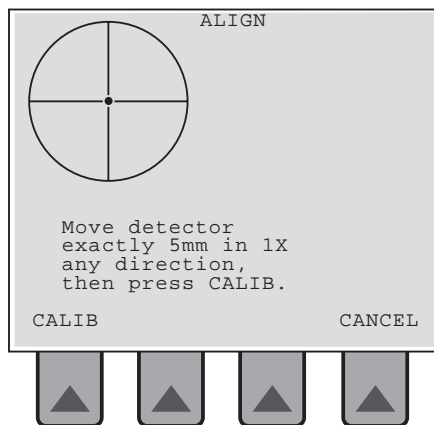

Figure 9. Calibrate 2 - Quadrant Thermal Detector Head CW

Screens: Quadrant Beam Position

Position Screen - The Beam Position Stability screen, shown in Figure 10, appears when, from the Home screen, the ALIGN soft key is pressed and then the POSITION soft key is pressed. This screen allows you to observe the positional stability of the beam over a selectable period of time.

On the left, beam position is shown as movement about the X axis (solid line) and Y axis (dotted line) over the selected duration. It is also shown on the right as a polar position plot on the detector.

Soft key functions on the Position screen are:

START - Starts data collection. At the end of the selected duration, the data collection screen appears (see Figure 11). Pressing Start clears the data and begins a new Position Trend run. (If required, the Time can be changed before beginning a new Position Trend run.)

Note that during data collection, the soft keys are replaced by a STOP soft key. Press the STOP key to halt data collection.

POWER - Returns you to the Home screen.

TIME - Allows you to select the duration of a run. When pressed, use the left and right cursor control keys to select the hours, minutes, or seconds field, and use INC (to increment) or DEC (to decrement) the selected field. Press ENTER to accept the displayed duration. Maximum value is 99 hours.

ALIGN - Returns you to the ALIGN, POSITION, CANCEL selection screen.

Screens: Quadrant Beam Position (cont'd)

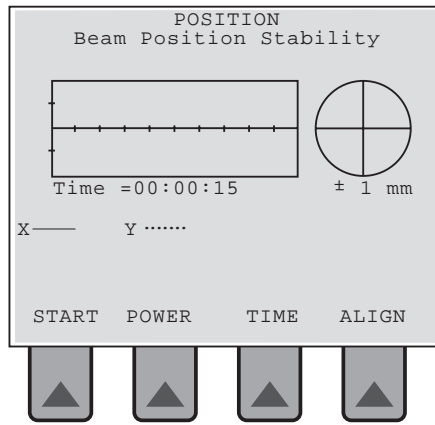

Figure 10. Beam Position - Quadrant Thermal Detector Head CW

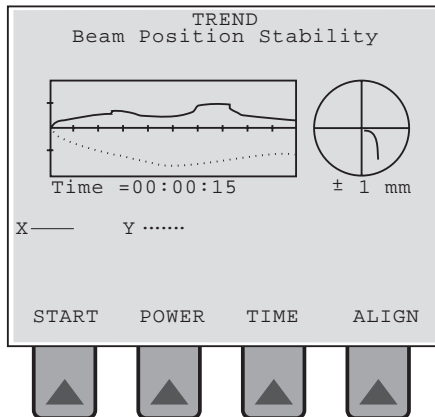

Figure 11. Beam Position Complete - Quadrant Thermal Detector Head CW

Screens: Quadrant Energy

Energy (Quadrant Thermal Detector Single Pulse Operation)

Press the ENERGY soft key on the Quadrant Thermal Detector CW Home screen to select single pulse measurement. This function allows you to enter a zero offset, after which the unit is ready for a single pulse measurement. When pressed, the Energy 1 screen is displayed as shown in Figure 12.

The Zero offset function must be performed for the first pulse and for maximum accuracy, a zero offset should be entered each time you press the ENERGY key and before a pulse is received. This screen shows the current or default setting for Wavelength and Attenuation. One soft key, ZERO, is available. Remove power from the detector before pressing ZERO. When Zero is pressed, the screen briefly displays the following message:

**OFFSET
ZEROED**

The display then changes and the Energy 2 screen appears as shown in Figure 13. In Figure 13, soft key functions are:

Clear - Resets the display for another pulse.

Zero - Resets the offset to zero.

Power - Returns the display to the Home screen.

Screens:
Quadrant
Energy
(cont'd)

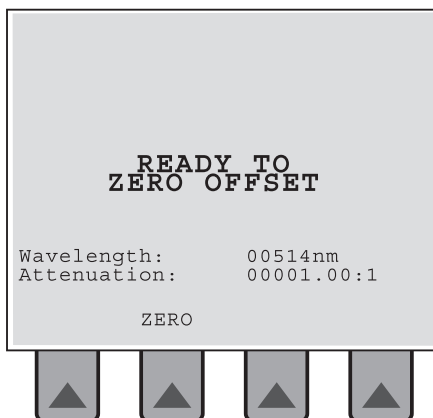

Figure 12. Energy 1 - Quadrant Thermal Detector Head CW

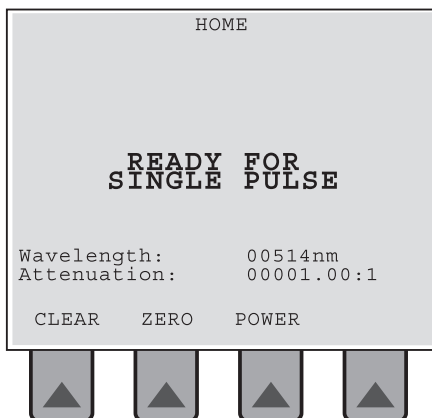

Figure 13. Energy 2 - Quadrant Thermal Detector Head CW

Screens: Non-Quadrant Home

Home Screen - Non-Quadrant Detector Head CW

The Home screen for a non-Quadrant Detector Head CW is shown in Figure 14. In this screen, power measurement is displayed in the upper half of the screen. Soft keys on this screen are discussed below.

Offset

Use the OFFSET soft key to compensate for ambient light. When first pressed, the screen displays the offset value. The second time the key is pressed, the offset value is returned to zero regardless of the power input at the time the key is pressed and the screen displays 0 offset.

Setup

Use the SETUP soft key to change the parameters for the Display Average, Wavelength and Attenuation. When Setup is pressed, Display Average is highlighted. Use the up and down cursor control keys to move the highlight up and down between the three parameters and the INC/DEC keys to change the value of the highlighted parameter.

Display Average - Enter the number of readings to be averaged for the displayed power or energy value. Valid entries are 1, 2, 5, 10, 20, 50, 100, and 200. Measurements are calculated at 10 Hz (i.e., 10 per second). The display is updated at 3 Hz with the value of the most recent measurement. The Display Average is the number of 10 Hz measurements to be used in the average using the running average method. The display itself is still updated at 3 Hz. (This also affects the trend function.)

Wavelength - Enter the wavelength of the laser measured. Use the left and right cursor control keys to move within the digits.

NOTE: This entry must be exact to insure accuracy.

Attenuation - Enter the amount of optical attenuation due to beam splitters, attenuators, or other optical elements. Use the left and right cursor control keys to move within the digits. (Attenuation affects the trend, tune and analog out.)

FieldMaster GS

Screens: Non-Quadrant Home (cont'd)

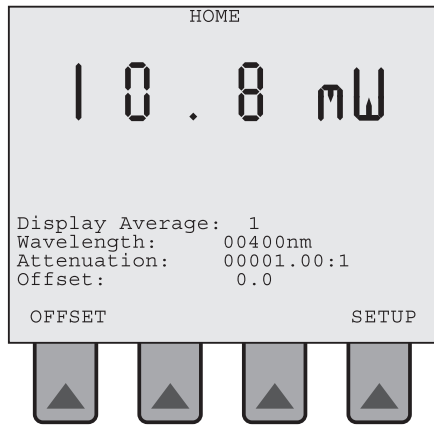

Figure 14. Home Screen - Non-Quadrant Thermal Detector Head CW

Press ENTER to accept the changes and return to the Home screen. As long as the same detector is connected, the values entered here are saved during On/Off cycles. If a different detector is installed, default values will be used until changed. To negate any changes and return to the Home screen, press ESCAPE.

Screens: Pulse Home

Home Screen - Pulse Detector

The Home screen for a Pulse Detector is shown in Figure 15. This screen displays the energy of the last pulse received and the frequency and average power of that pulse. Frequency is calculated based on the time between the last 2 pulses. Average power equals the energy of the last pulse multiplied by the frequency. The reading remains until either another pulse is received or the CLEAR soft key is pressed.

Note that if another pulse is not received immediately, a **WAITING FOR A PULSE** message appears. This message also appears after CLEAR is pressed.

Screens: Pulse Home (cont'd)

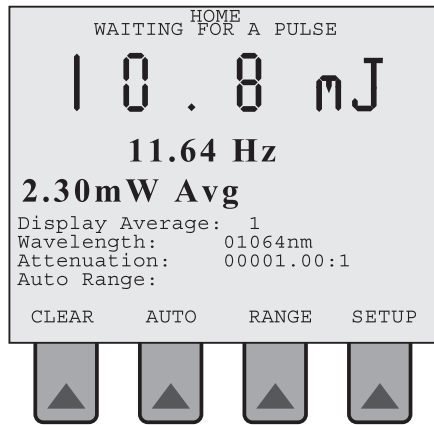

Figure 15. Home Screen - Pulse Detector

Pulse measurements are calculated at 10 Hz based on the last pulse received. The digital reading in both the Home function and Tune function displays is updated at 3 Hz with the measurement value of the last pulse. If pulses stop, the value of the last pulse measured will be displayed.

Soft keys on this screen are discussed below.

Clear

Use the CLEAR soft key to set the energy, frequency and power to zero and to set the Auto Range to the minimum range.

Auto

Use the AUTO soft key to change the Range scale to automatic mode. When pressed, the range scale resets the maximum allowable range to a variable within the limits of the detector. On the Home screen, the display shows **Auto Range**.

Screens: Pulse Home (cont'd)

Range

Use the RANGE soft key to manually set the energy range scale to a selectable fixed number. When pressed, the Pulse Home screen changes (see Figure 16). **Set Range xxx** is highlighted and the soft keys change to:

ESCAPE to exit the function without changes.

ENTER to exit the function and accept changes.

DEC to decrement the displayed range value.

INC to increment the displayed range value.

Note that pressing any Function key also exits this function. Also note that setting a manual Range will set the trigger level to 10% of that range. Note that setting the Range to Manual is intended for single pulse applications.

Setup

Use the SETUP soft key to change the parameters for the Display Average, Wave Length and Attenuation. When Setup is pressed, Display Average is highlighted. Use the up and down cursor control keys to move the highlight between the three parameters and the INC/DEC keys to change the value of the highlighted parameter.

Display Average - Enter the number of readings to be averaged for the displayed power or energy value. Valid entries are 1, 2, 5, 10, 20, 50, 100, and 200. Measurements are calculated at 10 Hz (i.e., 10 per second). The display is updated at 3 Hz with the value of the most recent measurement. The Display Average is the number of 10 Hz measurements to be used in the average using the running average method. The display itself is still updated at 3 Hz. (This also affects the trend function.)

Wavelength - Enter the wavelength of the laser measured. Use the left and right cursor control keys to move within the digits. **NOTE: This entry must be exact to insure accuracy.**

Attenuation - Enter the amount of optical attenuation due to beam splitters, attenuators, or other optical elements. Use the left and right cursor control keys to move within the digits. (This affects trend, tune and analog out.)

Screens: Pulse Home (cont'd)

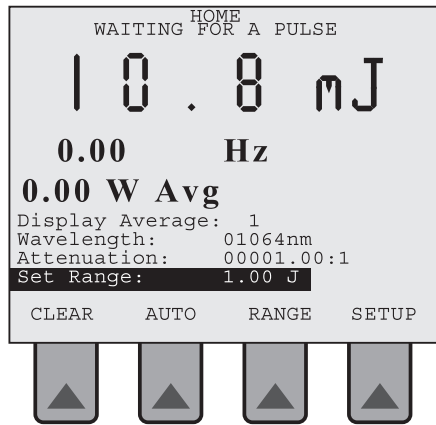

Figure 16. Set Range - Pulse Detector

Press ENTER to accept the changes and return to the Home screen. As long as the same detector is connected, the values entered here are saved during On/Off cycles. If a different detector is installed, default values will be used until changed. To negate any changes and return to the Home screen, press ESCAPE.

Screens: Tune

Tune Screen (CW and Pulse Detectors)

The Tune function is the same for CW and Pulse detector heads. The exception is that the measurement units are Watts for CW detectors and Joules for Pulse detectors.

When the Tune function key is pressed, the Tune screen appears (see Figure 17 for an example) and the analog needle swings up from the left corner of the display. The digital reading is updated at 3 Hz. The analog needle is driven by a D/A converter which is updated at 10 Hz.

The top portion of the screen displays the current measurement in large type. Immediately below this measurement, in smaller type, the peak measurement is displayed. The needle moves up as power increases and peak (maximum) power is indicated by a marker on the scale.

Soft key functions are described below.

FieldMaster GS

Screens: Tune (cont'd)

Reset

Press the RESET soft key to reset the peak power marker to the current needle position. This also resets the Auto ranging function.

Auto

Press the AUTO soft key to enable the automatic range feature. Note that range down only occurs when the Reset key is pressed. In Auto mode, Auto appears on the display just below the analog scale.

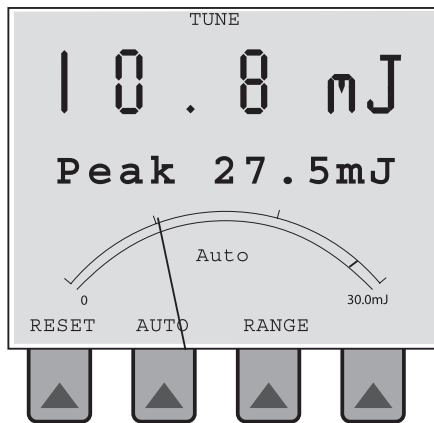

Figure 17. Tune Screen - Pulse Detector

Screens: Trend

Range

Press the RANGE soft key to manually set the full scale range to a selectable fixed number. The current full scale range (under the analog scale) is highlighted and the soft keys change to:

- ESCAPE to exit the function without changes;
- ENTER to exit the function and accept changes;
- DEC to decrement the displayed range value
- INC to increment the displayed range value

When in this mode, Manual appears on the display just below the analog scale.

Note that the current auto range scale or the selected manual range scale is displayed at the right side of the analog scale.

Trend Screen

The Trend screen provides two methods to monitor and analyze measurements: Plot (see page 28) and Scroll (see page 29). When the Trend function key is pressed, the Trend screen similar to Figure 18 appears.

Measurements are calculated at 10 Hz but only recorded and plotted for Interval, Duration, and number of points selected. The number of points is set by the user, while the Interval is dependent on the Duration setting and vice versa. That is, based on the number of points, changing the Interval and pressing Enter automatically changes the Duration and changing the Duration and pressing Enter automatically changes the Interval.

Trend data collection fills an array of 200 to 2000 points (array size is user selectable in 200 point increments). Trend data collection Duration is user selectable value from 20 seconds minimum to 99 hours (356,400 seconds) maximum. Duration value must be exactly divisible by the array size. Trend data collection Interval is user selectable from 0.1 second minimum to 29 min 42 sec (1782 sec.) maximum. Interval and duration are interdependent. Duration = product of the interval and selected array size. (Duration = Interval x Selected array size). e.g. selected array size is 200 points. Interval is 0.1 seconds. Duration therefore equals 20 seconds.

$$200 \times 0.1 \text{ sec.} = 20 \text{ sec.}$$

Screens: Trend (cont'd)

The display shows a graph and two columns of parameters, and the soft keys. This screen also gives you three methods of displaying the measured data: by plotting, statistically, and by histogram. Discussion of the Trend screen begins with the Setup soft key.

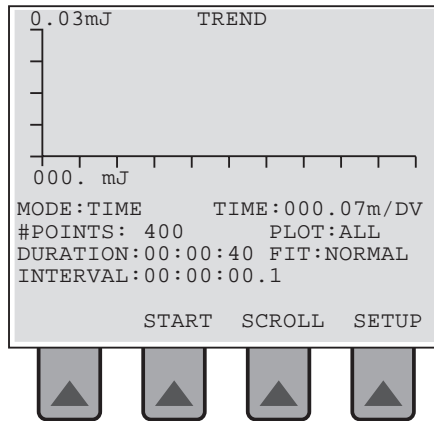

Figure 18. Trend Screen - Pulse Detector

Setup

Press SETUP to change the parameters shown on the display and discussed below. When pressed, #POINTS at the top of the left column is highlighted. Use the up and down arrows on the cursor control pad to highlight the item to be changed and the DEC/INC soft keys to decrement/increment the value for that item.

Parameter selection is top to bottom, left column to right column with full wrap around. Note that the DURATION item also uses the left and right cursor control keys to move within the field.

Parameters in the left column are:

MODE - With a CW Detector: This parameter cannot be changed from TIME mode. In the Time mode, the horizontal display is controlled by the Time Interval. Note that if no beam is present during a timed run, the last pulse collected will continue to be displayed.

Screens: Trend (cont'd)

With a Pulse Detector: The Mode can be toggled between TIME and PULSE using either the DEC or INC soft key. In the Time mode, operation is the same as with a CW Detector (see above) except that when the pulses stop, the Trend function continues to record the value of the last pulse measured. In the pulse mode, the Trend function measures and records the value for each pulse at the pulse rate up to 10 Hz. If the pulses stop, the measuring and display processes stop and then resume when the pulses begin again.

#POINTS - Use this parameter to set the number of points to be displayed, selectable from 200 to 2000 in 200 point increments.

DURATION - Use this parameter to set the duration of data collection. This is a user selectable value from a minimum of 20 seconds to a maximum of 99 hours. Allowed duration values must be exactly divisible by selected array size.

INTERVAL - Sets the interval between data collection points. Selectable in 0.1 second increments from 0.1 second to 29:42.0 (1782 sec.). Note that array size must be set to 200 in order to reach this interval.

Parameters in the right column are:

TIME - This parameter is determined by the number of points and either the interval or duration selected.

PLOT - Indicates whether the data points are all displayed or averaged (see pages 31 and 32)

FIT - Use this parameter when in the Trend Graph screen to toggle through three types of FIT.

When Setup is complete, press ENTER for selected setup parameters to take effect, or press ESCAPE to return to the previous Setup values.

Screens: Trend Scroll

Scroll

The SCROLL soft key on the Trend screen allows you to monitor measurements in a continuous mode. When pressed, measurements are collected and continuously presented, at the selected interval, beginning on the right of the graph. Figure 19 is an example of a Scroll which has collected more than 200 measurements. The last 200 are shown with the newest one entered on the right.

In Figure 19, the FASTER and SLOWER soft keys allow you to increase or decrease the Time/DV value of the TIME parameter which in turn corresponds to the divisions on the horizontal line of the graph. Note that in Pulse mode, the Scroll function stops if no pulses are received and then resumes when pulses resume.

The CANCEL soft key stops the Scroll function and returns to the Trend screen (Figure 18).

NOTE: Interval is the only set up function that affects the scroll screen. Other parameters can be changed, but they have no effect on the scroll function.

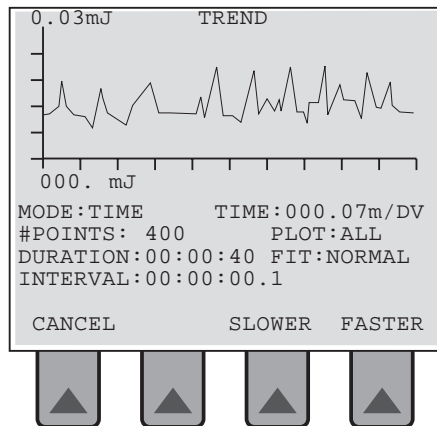

Figure 19. Scroll - Trend Screen

Screens: Trend Start

Start

Press this key to begin measurement collection using either the default settings for the parameters or the settings you entered through the Setup soft key. When pressed, measurements begin as observed on the graph and plotted continuously until a selected duration has been reached. A display similar to Figure 20 then appears.

During collection, the previous soft keys are replaced by a STOP soft key on the right. Pressing Stop halts data collection, returns you to the Trend screen (Figure 18), and you may view the statistics or histogram of the measurements collected or begin the process again.

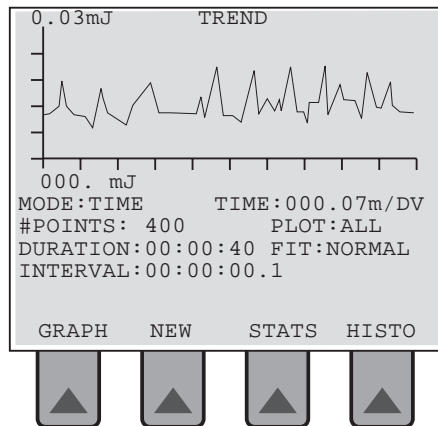

Figure 20. Start - Trend Screen - Pulse Detector

Screens: Trend Graph

Soft keys on Figure 20 are described below.

GRAPH - Press this key to graphically view the collected measurements as described below. When pressed, a screen similar to Figure 21 appears.

Press the TRENDS soft key to return to the completed Start screen (Figure 20).

Press the PLOT soft key to toggle between the following two methods of plotting the data.

ALL - Each measurement is plotted on the vertical axis at the point determined by dividing the total points by 200 horizontal points. For example, if 1000 total measurements are collected, points 1 through 5 will be plotted on the same vertical pixel column, points 6 through 10 on the next vertical pixel column, etc.

AVG - The necessary number of measurements to make 200 points are averaged. For example, if 2000 measurements are collected, each data point plotted will be the average of 10 measurements.

Press the FIT soft key to toggle through the following three types of FIT:

NORMAL - Sets the minimum and maximum values on the vertical axis of the graph to 0 and sets the range to the standard at which the measurement was collected.

+ 3 SIGMA - Sets the minimum and maximum values on the vertical axis of the graph equal to the + 3 standard deviations of the displayed measurements.

MIN/MAX - Sets the minimum and maximum values on the vertical axis equal to the minimum and maximum values of the displayed measurements.

Screens: Trend Graph (cont'd)

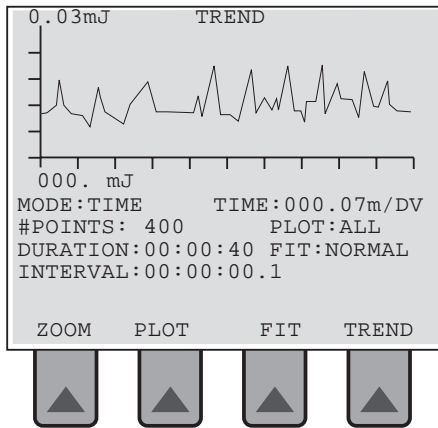

Figure 21. Graph - Trend Screen - Pulse Detector

Screens: Trend Zoom

Press the ZOOM soft key to select a particular 200 measurements to view. When pressed, the screen similar to Figure 22 appears.

Press the arrow soft keys to move the 200 measurement points window to the area of the graph you want expanded. Note that a single pressing of these keys moves the data window 10 points. You may also press and hold the key down until the window includes the desired measurement points. Just below the graph, the screen shows which 200 measurement points have been selected for expanded viewing. For example, in Figure 22, the data window includes measurement points 80 - 280.

Press the Select soft key. The 80 - 280 measurement points are expanded to the full width of the graph.

Press Return to go back to Figure 21 and then press Trend to return to the Trend screen shown in Figure 20.

Note that the Zoom soft key will not appear if the number of measurement points selected during Setup equals 200.

NEW - Press this key to return to the initial Trend screen to start another data collection process. **NOTE: Pressing New erases previously collected data. All data is lost if you exit the Trend Screen**

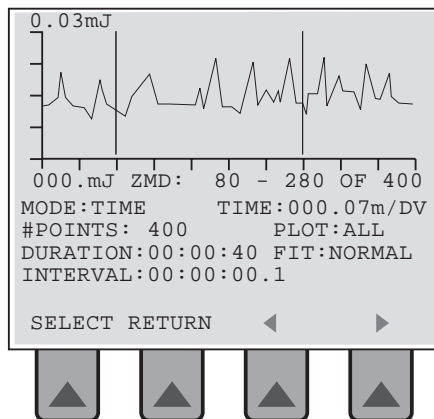

Figure 22. Zoom - Trend Screen - Pulse Detector

Screens: Trend Statistics

STAT - Press this soft key to view the statistical results of the data measured. The screen which appears will be similar to Figure 23 with a CW Detector.

It will also be the same for a Pulse Detector if, during Setup, Time is selected for the MODE parameter. (See Figure 18 and MODE description on page 27.) If Pulse is selected for the MODE parameter, the Statistical screen for a Pulse Detector will appear similar to Figure 24.

Pressing the TRENDS soft key returns you to the screen shown in Figure 20. This allows you to select another method of viewing the results of data collection within the same frame of data collection reference, or to start the process again.

Screens: Trend Statistics (cont'd)

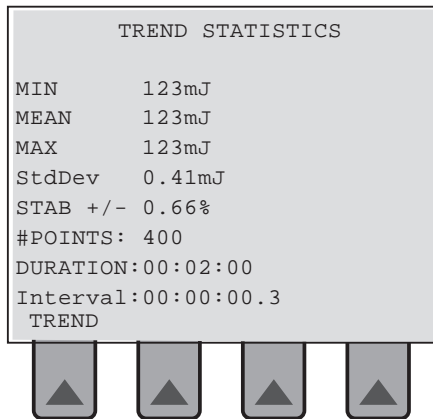

Figure 23. Trend Statistics Screen, Time Mode

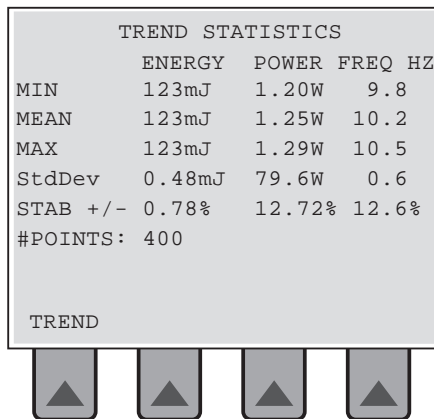

Figure 24. Trend Statistics Screen, Pulse Mode

Screens: Trend Histogram

HISTO - Press this soft key to view a histogram of the results of measurements collected. The screen which appears will be similar to Figure 25. Pressing the TREND soft key returns you to the Trend screen shown in Figure 20.

Note that the type of FIT previously selected determines the horizontal scaling on the Histogram.

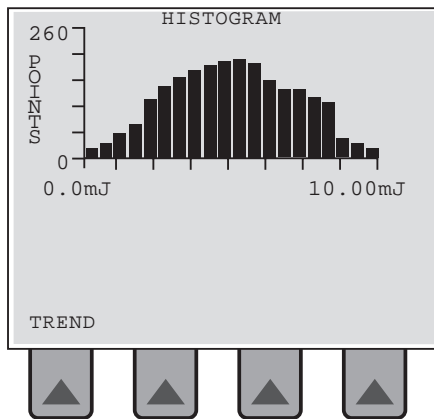

Figure 25. Histogram - Trend Screen - Pulse Detector

Remote Control Introduction

The remote control language used by the FieldMaster GS adheres as closely as possible to the IEEE-488.2 1987 standard. This standard was originally developed for the IEEE 488 (GPIB) bus, but many instruments, including the FieldMaster GS, have adopted the standard for RS-232 communication as well. All commands are through the RS-232 port set to 9600 baud.

Making the Software Connection

A program to communicate with the FieldMaster GS through the RS-232 port will need to be written. An example program is provided. The example program uses the COM2 serial port. If the computer is using a COM port other than COM2, a modification to the "OPEN COM2" statement to reflect the COM port actually being used will need to be made. The communication parameters used by FieldMaster GS are as follows:

Baud Rate	9600
Parity	none
Data Bits	8
Stop Bits	1

Message Exchange Protocol

The message exchange protocol is summarized as follows:

1. Tell the FieldMaster GS what to send to the computer.
2. Check for the correct character termination.
3. The complete response message must be received by the computer before another program message can be sent to the FieldMaster GS.

NOTE: The FieldMaster GS will only respond to RS-232 commands from the Home screen or the Trend screen. When in other screens RS-232 commands collected in the input buffer. Periodically returning to the Home or Trend screen will process buffered RS-232 commands. (Remaining in other screens can cause the input buffer to overflow.)

FieldMaster GS

Remote Control (cont'd)

Data Connections

Connections for data transmission between the FieldMaster GS and PCs are: FieldMaster GS TxD connects to the PC RxD; FieldMaster GS RxD connects to the PC TxD. Connector pin outs are:

FieldMaster GS RS-232 port is a DB 9 female connector. Pin assignments are:

- Pin 2 - TxD
- Pin 3 - RxD
- Pin 5 - GND

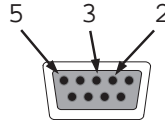

The PC RS-232 port(s) are either DB 9 or DB 25 male connectors. DB 9 male connector pin assignments are:

- Pin 2 - RxD
- Pin 3 - TxD
- Pin 5 - GND

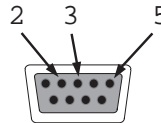

DB 25 male connector pin assignments are:

- Pin 2 - TxD
- Pin 3 - RxD
- Pin 7 - GND

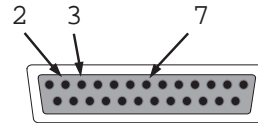

For IBM PC compatible serial ports, use a straight through cable. The FieldMaster GS uses a 9-pin serial connector. Depending on the computer, either a 9-pin-to-9-pin cable or a 9-pin-to-25-pin cable will be needed. Typical pin outs are:

9-pin to 9-pin				25-pin to 9-pin			
Label	Pin	Pin	Label	Label	Pin	Pin	Label
Computer			FM-GS	Computer			FM-GS
DCD	1	1		DTR	20	1	
RX	2	2	TX	RX	3	2	TX
TX	3	3	RX	TX	2	3	RX
DTR	4	6		DSR	6	4	
GND	5	5	GND	DCD	8	6	GND
DSR	6	4		GND	7	5	
RTS	7	7		CTS	5	7	
CTS	8	8		RTS	4	8	
RI	9	9		RI	NC	9	

Remote Control (cont'd)

Remote Control Language Syntax

One or more command words make up the program message that is sent to the FieldMaster GS to perform one or more operations.

Commands and Command Parameters

Both common commands and FieldMaster GS commands may or may not use a parameter. For example:

rn 2e-3	Parameters 2e-3 required
*ind?	Returns model
*rst	No parameter used

Note that there must be a space between the command word and the parameter. Parameter types are listed in the following table:

Parameter	Type	Example	Action
ON/OFF	Boolean: Used to enable or disable an instrument operation. OFF disables operation; ON enables operation.	of on of off	Sets offset to ON Sets offset to OFF
T/P	Explicit: Two or more explicit parameters to choose from; T or P.	tp t	Sets trigger to Time
####	Numeric representation format. Parameter is a number that can be expressed as an integer (e.g., 8), a real number (e.g., 10.6), or an exponent (e.g., 23e3).	rn, 2e-3	Sets Range to .002
"hh:mm:ss"	String data.	td "00:15:00"	Sets Trend Duration to 15 minutes

FieldMaster GS

Remote Control (cont'd)

Query Commands

This type of command requests (queries) the currently programmed status. It is identified by the question mark (?) at the end of the fundamental form of the command. Most commands have a query form. For example:

td "00:15:00"	Set Trend Duration to 15 minutes
td?	Request Trend Duration

Case Sensitivity

Use lower case for all commands.

Program Messages

A program message is made up of one or more command words sent by the computer to the FieldMaster GS. Examples:

Single command messages - The commands in this structure can be executed by sending two separate program messages as;

```
tp 500\n
td "00:15:00"\n
```

Program message terminator - Each program message must be terminated with a backslash and the termination character determined by the computer and selected in the Menuscreen. Examples are:

```
\r - Carriage Return
\n - Linefeed
```

Remote Control (cont'd)

Remote Control Commands

All commands and queries are in ASCII text. All commands and queries comply with the ANSI/IEEE 488.2, 1987 Standard. In general, the rules listed in the table below apply to the formatting of data that is sent or received on the bus.

Data Type	Definition	Example
Numeric	Numeric data may consist of digits, a decimal point, a leading sign (i.e., + or -), and an exponent with or without a leading sign.	123, -0.0123, 1.23e-2
Character	Character data may consist of alphabetic characters, digits, and underscores, although it must begin with an alphabetic character.	abc, a_b_c, a1, b2, c3
String	String data allows any 7-bit ASCII character. This includes alphabetic characters, digits, and all punctuation characters. String data MUST be delimited by either single or double quotation marks.	"11/10/98", "10:30:00"
Arbitrary	Arbitrary ASCII data may include 8-bit ASCII values. It does not require any delimiters, but it must be the LAST value in a transmission. In the FieldMaster GS, the only item that uses the arbitrary ASCII data format is the IEEE-488.2 mandated query "*idn?".	Coherent, Inc. FieldMaster GS, 0, 2.00

To send a command, copy the command into a text string and pass the string to the function that will write the string to the RS-232 port.

The type of remote control commands for the FieldMaster GS are listed below and shown in tabular format on the following pages.

- System Configuration Commands
- System Configuration Queries
- Data Collection Commands
- Data Collection Queries

Remote Control (cont'd)

Remote Control Error Codes

The err? query will return error codes as shown. If there are no errors, the query response is zero. When an error occurs, the error code is stored until it is asked for, or a new error occurs. After the err? query is responded to, the error code is cleared. If the error code is not read and a new error occurs, the old error code is replaced by the new error code. This means the error code will always reflect the last error that occurred.

Command Errors

Code	Error	Probable Cause
1-6	Unused	
7	Not a valid command or query	
8	Unused	
9	Parameter value is invalid	A non-numeric parameter was misspelled
10	Parameter out of range	A numeric parameter is outside the valid range for the specified operation
11	No detector connected	An operation was requested and no detector is connected
12	Request not valid for current detector	A pulsed operation was requested for a CW detector, or a CW operation was requested for a pulse detector.
13	Requested data not available	New data has not been collected since the system was cleared or powered up.
14-16	Unused	

Remote Control (cont'd)

Remote Control Screen Display

All parameter changes are applied independently of the screen displayed when parameters are changed via RS-232 commands.

When Trend or Position parameters have been changed via RS-232, the changes do not appear on the FieldMaster-GS display until a Trend or Position run is started (using the "ts" command).

When Home screen parameters are changed via RS-232 commands, the changes do not appear on the FieldMaster-GS display until the Home button on the FieldMaster console is pressed or another function is ended.

In all cases, the parameter changes are actually made and in effect immediately after the RS-232 command is sent.

System Configuration Commands

Restart system (*rst)

Header: *rst - restart system
Example: Reboot the system
 ***rst**

Set wavelength (wv)

Header: wv - set wavelength
Parameters: wavelength, meters (###e##)
Ranges: (determined by detector)
Example: Set the wavelength to 532 nm
 wv 5.32e-9

Set attenuation (at)

Header: at - set attenuation
Parameters: attenuation (###e##)
Ranges: attenuation range 1.00 to 100,000.0
Example: To set the attenuation to 100:1
 at 100 or at 1.0e²

Remote Control (cont'd)

Set range (rn)

Header: rn - set range
Parameters: range (###e##)
Ranges: Valid range depends on the detector and attenuation. Input range of 0 (zero) = autorange.
Example: To set the range to 2 mW
rn 2e-3

NOTE: This command is only used for Pulse detectors.

Set offset (of)

Header: of - set offset
Parameters: On/Off
Ranges: Only On or Off allowed. When On, current reading becomes the offset.
Example: To set the Offset to the current reading
of on

Set number of readings to average (pa)

Header: pa - set readings to average
Parameters: readings (###)
Ranges: Valid ranges are: 1, 2, 5, 10, 20, 50, 100, 200
Example: To set the average to 10 readings
pa 10

FieldMaster GS

Remote Control (cont'd)

System Configuration Queries

Identify system (*ind)

Header: *ind - identify system
Returns: FieldMaster GS (text string)
Example: Request system identification
***ind**
Response **FieldMaster GS**

Request detector type (dt?)

Header: dt? - query detector
Returns: detector (text string, delimited by double quote marks[""])
Example: Request the detector type
dt?
Response **"LM-10"**

Request wavelength setting (wv?)

Header: wv? - query wavelength
Returns: wavelength in meters (#.#####e##)
Example: Request the wavelength
wv?
Response **5.320000e-07**

Request attenuation (at?)

Header: at? - query attenuation
Returns: attenuation (#####.## - value between 1.00 and 100,000.0)
Example: Request the attenuation
at?
Response **100**

Remote Control (cont'd)

Request range (rn?)

Header: rn? - query range
Parameters: none
Returns: range (#####e##)
Ranges: none
Example: Request the range
rn?
Response **2.000000e-03**

NOTE: This command is only used for Pulse detectors.

Request offset (of?)

Header: of? - query offset
Parameters: none
Returns: offset (#####e##)
Ranges: none
Example: Request the offset
of?
Response **1.714718e-06**

Request number of readings averaged (pa?)

Header: pa? - query readings to average
Parameters: none
Returns: readings (###)
Ranges: none
Example: Request readings to average
pa?
Response: **10**

Remote Control (cont'd)

Data Collection Commands

Set trigger type (tr)

Header: tr - set trigger type
Parameters: type (**T**, **P**)
Ranges: Trigger types are T(ime) and P(ulse)
Example: Set trigger on Time intervals
tr t

NOTE: "P" option only valid for pulse type detectors.

Set number of trend points (tp)

Header: tp - trend points to collect
Parameters: pts (####)
Ranges: Number of points from 200 to 2000, multiples of 200
Example: Set to collect a Trend run of 400 points
tp 400

Set trend duration (td)

Header: td - set trend duration
Parameters: dur ("**hh:mm:ss**" - text string delimited by quotes)
Ranges: Duration ranges from "00:00:20" to "99:00:00".
Example: Set the duration of Trend data collection to 15 minutes (00:15:00).
td "00:15:00"

NOTE: Duration must be exactly divisible by number of trend points. Parameter value will be set to the closest value to the entered value that is exactly divisible by the number of trend points.

Set trend interval (ti)

Header: ti - set trend interval
Parameters: interval ("**mm:ss.s**" - text string delimited by quotes)
Ranges: Interval ranges from "00:00.1" to "29:42.0".
Example: Set the interval between points of data collection to 5 seconds (00:05.0).
ti "00:05.0"

Remote Control (cont'd)

Start trend data collection (ts)

Header: ts - start trend data collection
Parameters: none
Ranges: none
Example: Start Trend data collection.
ts

NOTE: Once in progress, any RS-232 command or character will stop data capture and the FieldMaster GS returns "**trend stopped by serial port command**".

Stop trend data collection (te)

Header: te - stop trend data collection
Parameters: none
Ranges: none
Example: Stop Trend data collection.
te

NOTE: Any RS-232 command will stop Trend data capture. If this command is sent when the FieldMaster GS is in the Trend screen but not in active data collection, it will return the FieldMaster GS to the Home screen.

Set position run duration (pd)

Header: pd - set position run duration
Parameters: duration ("hh:mm:ss" - text string delimited by quotes)
Ranges: Duration ranges from "00:00:30" to "99:59:59".
Example: Set the duration for Position measurement run to 15 minutes (00:15:00).
pd "00:15:00"

Start position run (ps)

Header: ps - start position run
Parameters: none
Example: Start Position measurement run.
ps

Remote Control (cont'd)

Stop position run (pe)

Header: pe - stop position run
Parameters: none
Ranges: This command is only valid for Quad type detectors.
Example: Stop Position measurement run.
pe

Start CW energy (cw)

Header: cw - start
Parameters: none
Ranges: none
Example: **cw**

Zero before CW energy readings (cwz)

Header: cwz - zero
Parameters: none
Ranges: none
Example: **cwz**
Note: >2 seconds time out required before a pulse.

Clear pulse for next pulse in CW energy (cwc)

Header: cwc - start
Parameters: none
Ranges: none
Example: **cwc**
Note: >2 seconds time out required before a pulse.

Exit from CW energy screen (cwe)

Header: cwe - end cw energy
Parameters: none
Ranges: none
Example: **cwe**

Remote Control (cont'd)

Help on available commands (h)

Header: h - help
Parameters: none
Ranges: none
Example: **h**

NOTE: This command produces a list of valid commands and a brief description of each (see Appendix C).

Data Collection Queries

Request power reading (pw?)

Header: pw? - query power
Parameters: none
Returns: pwr (#####e##)
Ranges: none
Example: Request the current power reading.
pw?
Response: **1.430000e-03**

Request energy reading (en?)

Header: en? - query energy
Parameters: none
Returns: energy (#####e## - If detector is pulse.)
Ranges: none
Example: Request current energy reading.
en?
Response: **1.438641e-03**

Remote Control (cont'd)

Request frequency (ff?)

Header: ff? - query frequency
Parameters: none
Returns: freq (#####e##)
Ranges: none
Example: Request the current frequency measurement.
ff?
Response: **2.000000e-01**
NOTE: This command is for Pulse detectors only.

Request trend run number of points (tp?)

Header: tp? - query number trend points collected
Parameters: none
Returns: pts (##### - number of points currently in trend buffer. **NOTE:** This may be less than the number requested if collection has not been completed. The Trend run is complete when the number of points collected equals the number of points set.)
Ranges: none
Example: Request the current number of points collected in a Trend run.
tp?
Response: **100**

Request trend interval (ti?)

Header: ti? - query interval between trend data points
Parameters: none
Returns: data collection interval "mm.ss.s".
Ranges: none
Example: Request the interval between the first and second trend points.
ti?
Response: **"00:05.0"**

Remote Control (cont'd)

Request trend frequency (tf?)

Header: tf? - query frequency for a point in a trend run
Parameters: point (#### - 1 to 2000)
Returns: frequency in Hz
Ranges: point must be between 1 and 2000
Example: Request the frequency of the 2nd point in the current trend run.

tf? 2

Response: **150**

Request trend duration (td?)

Header: td? - query duration of trend collection
Parameters: none
Returns: duration ("**hh:mm:ss**" - duration of trend run)
Ranges: none
Example: Request the duration of the trend data collection run.

td? 2

Response: **"00:15:00"**

Request trend data point value (tv?)

Header: tv - query value of trend data point
Parameters: point (#### - 1 to 2000)
Returns: value in joules or watts (**#.#####e##**)
Ranges: point must be between 1 and 2000
Example: Request the value of the 1st point in the trend run.

tvf? 1

Response: **1.520000e-03**

Request position trend point value (po?)

Header: po? - query current position
Parameters: none
Returns: x, y (**##.###, ##.###** - location in mm)
Ranges: none
Example: Request the current position reading.

po?

Response: **00.984, 00.731**

Remote Control (cont'd)

Request position run interval (pi?)

Header: pi? - query interval between points in position run
Parameters: none
Returns: data collection interval "**mm:ss.s**"
Ranges: none
Example: Request the interval between the 1st and 2nd points in the position run.
pi?
Response: "**00:15.0**"

Request position run duration (pd?)

Header: pd? - query duration of position run
Parameters: none
Returns: duration ("**hh:mm:ss**" - in seconds)
Ranges: From "**00:00:30**" to "**99:59:59**".
Example: Request the duration of the current position run.
pd?
Response: "**00:15:00**"

Request position run data point value (pv?)

Header: pv? - query position of point
Parameters: point (#### - 1 to 170)
Returns: x, y (##.###, ##.### - location in mm)
Ranges: point must be between 1 and 170.
Example: Request the value of the 1st point in the position run.
pv? 1
Response: **00.984, 00.731**

Remote Control (cont'd)

Request trend stats - average power (tpa?)

Header: tpa? - query trend average power
Parameters: none
Returns: average power in watts (#####e##)
Ranges: From "00:00:30" to "99:59:59".
Example: Request the trend average power.
tpa?
Response: **1.550000e-03**

Request trend stats - maximum power (tpm?)

Header: tpm? - query trend maximum power
Parameters: none
Returns: power in watts(#####e##)
Ranges: none
Example: Request the trend maximum power.
tpm?
Response: **2.010000e-03**

Request trend stats - minimum power (tpl?)

Header: tpl? - query trend minimum power
Parameters: none
Returns: power in watts (#####e##)
Ranges: none
Example: Request the trend minimum power.
tpl?
Response: **1.210000e-03**

Request trend stats - standard power deviation (tpd?)

Header: tpd? - query trend standard power deviation
Parameters: none
Returns: power in watts (#####e##)
Ranges: none
Example: Request the standard power deviation.
tpd?
Response: **4.510000e-06**

Remote Control (cont'd)

Request trend stats - power 2sigma stability (tps?)

Header: tps? - query trend 2sigma stability
Parameters: none
Returns: stability (#####e##)
Ranges: none
Example: Request the trend power stability.
tps?
Response: **2.300000e-00**

Request trend stats - average energy (tea?)

Header: tea? - query trend average energy
Parameters: none
Returns: energy in joules (#####e## - if detector is pulse)
Ranges: none
Example: Request the trend average energy.
tea?
Response: **1.550000e-03**

Request trend stats - maximum energy (tem?)

Header: tem? - query trend maximum energy
Parameters: none
Returns: energy in joules (#####e## - if detector is pulse)
Ranges: none
Example: Request the trend maximum energy.
tem?
Response: **2.010000e-03**

Request trend stats - minimum energy (tel?)

Header: tel? - query trend minimum energy
Parameters: none
Returns: energy in joules (#####e##)
Ranges: none
Example: Request the trend minimum energy.
tel?
Response: **1.210000e-03**

Remote Control (cont'd)

Request trend stats - standard energy deviation (ted?)

Header: ted? - query trend standard energy deviation
Parameters: none
Returns: energy in joules (#####e##)
Ranges: none
Example: Request the trend standard energy deviation.
ted?
Response: **4.510000e-06**

Request trend stats - energy 2sigma stability (tes?)

Header: tes? - query trend energy 2sigma stability
Parameters: none
Returns: stability (#####e## - if detector is pulse)
Ranges: none
Example: Request the trend energy stability.
tes?
Response: **2.300000e-00**

Request trend stats - frequency average (tfa?)

Header: tfa? - query trend average frequency
Parameters: none
Returns: frequency (#####e##)
Ranges: none
Example: Request the trend average frequency.
tfa?
Response: **2.000000e-01**

Request trend stats - frequency maximum (tfm?)

Header: tfm? - query trend maximum frequency
Parameters: none
Returns: frequency (#####e##)
Ranges: none
Example: Request the trend maximum frequency.
tfm?
Response: **2.020000e-01**

Remote Control (cont'd)

Request trend stats - frequency minimum (tfl?)

Header: tfl? - query trend minimum frequency
Parameters: none
Returns: frequency (#####e##)
Ranges: none
Example: Request the trend maximum frequency.
tfl?
Response: **1.990000e-01**

Request trend stats - standard frequency deviation (tfd?)

Header: tfd? - query trend standard frequency deviation
Parameters: none
Returns: frequency (#####e##)
Ranges: none
Example: Request the trend standard frequency deviation.
tfd?
Response: **0.010000e-00**

Request trend stats - frequency 2sigma stability (tfs?)

Header: tfs? - query trend 2sigma stability frequency
Parameters: none
Returns: energy (#####e##)
Ranges: none
Example: Request the trend frequency stability.
tfs?
Response: **2.300000e-00**

FieldMaster GS

Simple RS-232 Program Example

- ` Program to read FieldMaster GS power through the RS-232
- ` Displays current, min and max.
- ` Written for Microsoft QBasic v 1.0 (the one that comes free with DOS)

```
DECLARE FUNCTION GetInput$ ()

COMMON SHARED term$           ` Termination Character string

` FieldMaster GS can be set to terminate 4 different ways
`term$ = "\"                   ` for \ line termination
`term$ = CHR$(13)              ` for CR line termination
`term$ = CHR$(13) + CHR$(10)   ` for CR-LF line termination
term$ = CHR$(10)               ` for LF line termination

CLS
LOCATE 1, 5
PRINT "FieldMaster GS RS-232 demo program"

` Change the com port and baud rate as required
OPEN "com1:9600,n,8,1,CD0,CS0,DS0,OP0,RS" FOR RANDOM AS #1

` Setup screen
LOCATE 23, 10
PRINT "Press any key to stop";
LOCATE 8, 21
PRINT "Current"
LOCATE 8, 36
PRINT "Min"
LOCATE 8, 51
PRINT "Max"
LOCATE 10, 5
PRINT "Power = ";

` Set min/max values to extremes
pwrMin = 1000000!
pwrMax = 0!
```

FieldMaster GS

Simple RS-232 Program Example (Cont'd)

```
` Get Configuration information
PRINT #1, "v" + term$; ` request software version number
vers$ = GetInput$
LOCATE 2, 5
PRINT vers$;

PRINT #1, "dt?" + term$; ` request current detector name
detr$ = GetInput$
LOCATE 4, 5
PRINT "Detector = ";
PRINT detr$;

PRINT #1, "wv?" + term$; ` request current wavelength
wvln$ = GetInput$
LOCATE 5, 5
PRINT "Wavelength = ";
PRINT wvln$;
PRINT " meters"

WHILE INKEY$ = "" ` Update until a key pressed
    PRINT #1, "pw?" + term$;
    pwr$ = GetInput$
    power = VAL(pwr$) ` convert string to number for compares
    LOCATE 10, 20
    PRINT USING "##.##^"; power
    IF power > pwrMax THEN
        pwrMax = power
        LOCATE 10, 50
        PRINT USING "##.##^"; pwrMax
    END IF
    IF power < pwrMin THEN
        pwrMin = power
        LOCATE 10, 35
        PRINT USING "##.##^"; pwrMinTurn
```

FieldMaster GS

Simple RS-232 Program Example (Cont'd)

```
        END IF
WEND

` This function reads one character at a time from the com port until
` a termination character is rec'd.  It returns the string without any
` the linefeeds or carriage returns.
FUNCTION GetInput$

    done% = 0

    ` Look for last character in termination string
    end$ = RIGHT$(term$, 1)

    DO

        temp$ = INPUT$(1, 1)

        ` Dynamically determine correct terminator???
        `IF temp$ = "\" THEN end$ = "\"
        `IF temp$ = CHR$(13) THEN end$ = CHR$(13)
        `IF temp$ = CHR$(10) THEN end$ = CHR$(10)

        ` Finish input on termination character
        IF temp$ = end$ THEN
            done% = 1
            GetInput$ = resp$
        END IF

        ` Strip CR and LF characters.
        IF temp$ <> CHR$(10) AND temp$ <> CHR$(13) THEN
            resp$ = resp$ + temp$
        END IF

    LOOP UNTIL done%

END FUNCTION
```

FieldMaster GS

Determining Firmware Version

Turn the FieldMaster GS on and press the MENU key. From the Menu screen, use the up and down cursor control keys to select SYSTEM STATUS and then press INC/ON. The version number will be shown (e.g. 1.20) just above the EXIT soft key. Newer detectors may require current firmware to operate. For firmware updates, contact Service (see the last page of the manual).

Maintenance

Cleaning the Graphic Screen Window

To reduce the effect of static electricity on the analog meter movement, please clean the window with the enclosed antistatic cloth only.

Battery Replacement

The FieldMaster GS comes with a Nickel-Cadmium rechargeable battery pack. The unit has a built-in battery charging circuit. If the battery pack requires replacement, either contact Coherent for replacement instructions or return the unit to Coherent for replacement.

FieldMaster GS

Trouble Shooting

PROBLEM	PROBABLE CAUSE	SOLUTION
Unable to turn FieldMaster GS On	Dead battery	Use AC Adapter while batteries charge
	Unit faulty	Contact Coherent Service
No Detector message	Detector not plugged in	Plug detector in
	Detector faulty	Contact Coherent Service
	Cable faulty	
	Unit faulty	
OVER TEMP message.	Detector head is over specified maximum temperature	Turn energy/power down
		Attenuate beam
		Remove Detector from beam
Backlight not on	Not turned on in Menu function	Turn On in Menu function
	Display faulty	Contact Coherent Service.
Needle not registering	Not in tune screen	Go to tune screen
	Unit faulty	Contact Coherent Service
Battery won't hold a charge	Batteries or unit faulty	Contact Coherent Service
Over power message	Power has exceeded the range of the Detector	Reduce power or install a Detector with appropriate power range
Serial communication problems		Ensure host baud rate = 9600, stop bit = 1, parity = none. To determine that you have communications, issue h to the unit and it will return the list of commands available.
Analog out issues		The load resistance should be >150K ohms for 1% accuracy. See the AlogOut selection in the MENU function to set the range.
False pulse trigger.	High ambient levels of 60 Hz EMI	Ground detector to AC ground
Pulse head manual range trigger	When using Auto range, up to three pulses of the same amplitude may be required before the correct range is determined and a measurement displayed. In Manual range, the first pulse issued will be measured and recorded as long as it is greater than 10% of the full scale range value.	

FieldMaster GS

Specifications

Display Type:	High speed, high contrast, back lit liquid crystal display (240 x 200 pixels)
Display Options:	Software control of contrast, normal or reverse display screen backlighting
Ranges:	Microprocessor controlled. Display ranges determined by EEPROM in sensor heads. No range limitation on display.
Digital Display:	< 3 Hz update rate (3 significant digits)
Analog Display:	10 Hz update rate (needle movement)
Display Accuracy:	$\pm 1\%$ (must be added to detector accuracy for total system accuracy)
Display Average:	User selectable 1 - 200
RS-232 Interface:	Full remote capability and data transfer (9600 baud)
Analog Out:	0-1 Volt, $\pm 2\%$, 5 Hz update rate
Pulse Detector:	1 Khz Maximum pulse rate. 10 Hz Maximum every pulse capture rate for trend and statistics screens (> 10 Hz sampling at 10 Hz).
CW Thermal Detector:	Single pulse detection (10% accuracy without calibration). Readout averaging. Beam Alignment. Position measurement (5% at 5mm – built in calibration).
Trend:	2000 points pulsed or time acquisition modes.
Statistics:	10 Hz acquisition for CW detectors. Up to 10 Hz sampling rate.
Memory:	Retains configuration information when turned off (wavelength values, display information, etc.).
Operating Temperature:	5° C to 40° C

FieldMaster GS

Specifications (cont'd)

Safety Features: Visual sensor over-temperature and sensor over-range warning. Has protective cover which doubles as a standup base. An optional soft carrying case is also available.

Size: 7.6" long x 4.6" wide x 1.8" thick, when closed (19 cm x 11.7 cm x 4.6 cm).

Weight: 28 ounces, w/batteries.

Power

Requirements:

AC operation

115 VAC or 230 VAC
50/60 Hz 50/60 Hz
2 VA 2 VA

DC operation

9 VDC, 0.4A, (7.5V Internal rechargeable battery pack. Recharged automatically during AC operation. Battery life: 8 hours without backlight on; 4 hours with backlight on.

**Appendix A:
FieldMaster GS Block Diagram
and Circuit Operation**

FieldMaster GS

Block Diagram

Each power (detector) head contains a temperature sensor, electrically erasable programmable read only memory (EEPROM) and either a photodiode, thermopile, or pyroelectric cell. At power On, the program interrogates the EEPROM to determine which type of detector is present.

Amplifier gains and analog switches (mux) are adjusted to match the information received from the EEPROM. The 16-bit analog-to-digital converter (A/D) switches between channels 1 and 2 to measure either sensor output or temperature. This data is then sent through the Interface to the Microprocessor.

The program in the Microprocessor controls the mux, amplifier gains, and A/D converter channels. Display, read only memory (ROM), random access memory (RAM), and Interface electronics are selectively reached by the Microprocessor through the Decoder. The Decoder interprets the Microprocessor address lines to determine which device the Microprocessor wants to talk to.

All signals coming from or going to sources external to the Microprocessor (front panel switches, head sensor data, analog output, meter drive, and speaker) go through the Interface. The Interface provides the conduit through which the Microprocessor talks to the outside world.

An LCD controller provides display refresh from display memory and the Interface to the Microprocessor. When data needs to be written to the display, the controller writes the data to display memory between display update cycles.

Power Head

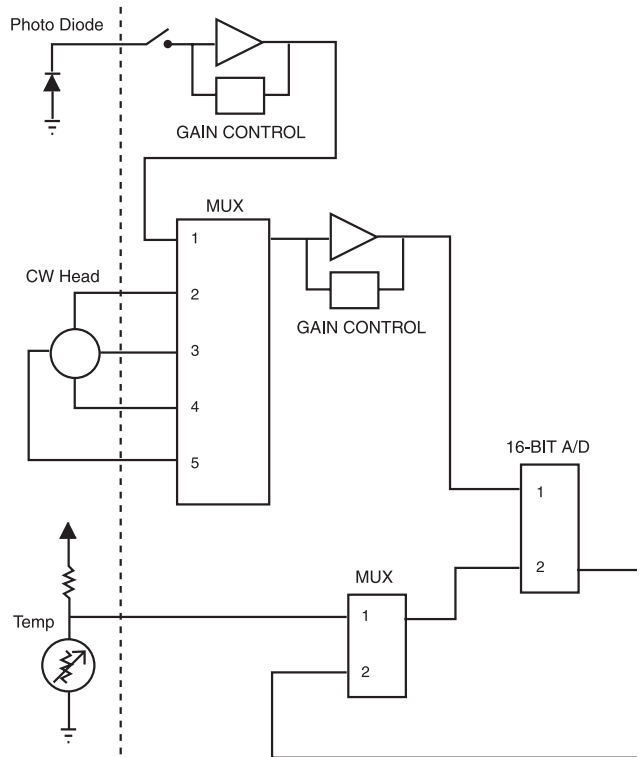

Pulse Head

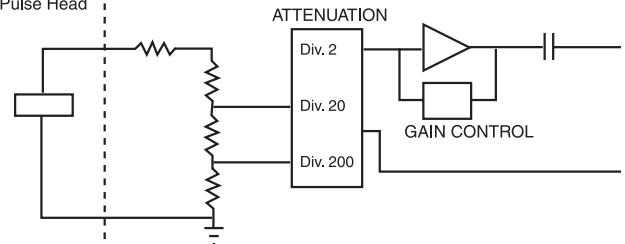

EEPROM

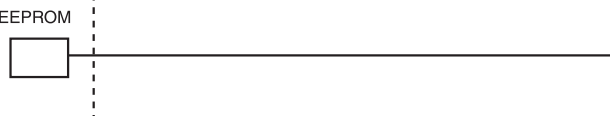

FieldMaster GS

FieldMaster GS Block Diagram

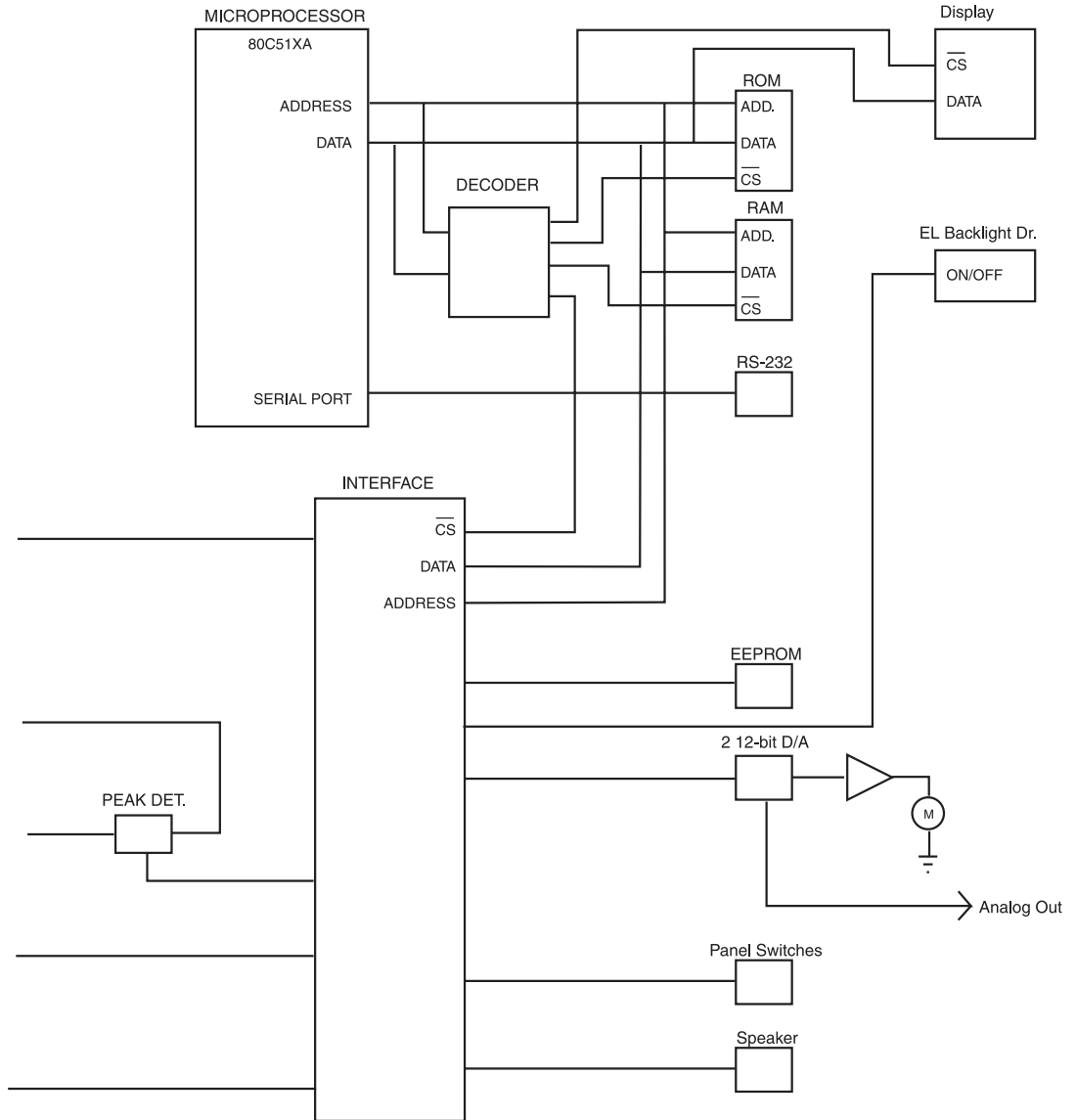

Operation

The thermoelectric detector heads have four outputs that determine beam position and laser power. The Microprocessor scans the mux through the four outputs and the temperature signal to arrive at a power reading (with the Gain Amplifier set to provide maximum signal strength). The A/D then converts the outputs for the Microprocessor.

Photodiode detector heads have one output. They use a current-to-voltage converter to precondition the output before it reaches the Gain Amplifier. The A/D then converts the output for the Microprocessor.

Pyroelectric detector heads require a 1 M ohm input to work correctly. This is provided by a resistive divider for the load and to attenuate the signal. Gain changes are made through an amplifier which is AC coupled to a Peak Detector that measures the pulse peak energy. The output is then connected to the A/D to convert it for the Microprocessor.

Both the Analog output and the meter are driven by a digital-to-analog (D/A) converter using data provided by the Microprocessor. The FieldMaster GS is calibrated at the factory and it stores these calibration values in an on-board EEPROM.

Rechargeable batteries are provided. The FieldMaster GS can be operated with the external power supply and simultaneously recharge the batteries.

A user adjustable automatic shutdown timer controls how long the FieldMaster will stay fully powered up between key presses. This feature, designed to conserve battery power, is automatically disabled when the external power supply is connected.

Appendix B: Help File

FieldMaster GS

Help File

The help file, available through a computer connected to the RS-232 bus, is as follows:

Valid commands: (spaces are significant)

a	- read the 16 bit adc
at <float attenuation>	- set the attenuation value
at?	- read the attenuation value
b	- test the buzzer
cw	- start cw energy
cwc	- clear cw energy
cwz	- zero cw energy
cwe	- end cw energy
dt?	- read detector name
en?	- read energy
h	- show this HELP
of <on/off>	- set the offset value to current/zero
of?	- read the offset value
pa <readings to average>	- set the display average value
pa?	- read the display average value
pd <"hh:mm:ss">	- set position run duration
pd?	- send position run duration
pe	- end position run
po? <number>	- send position value at index
ps	- start position
pv?	- send current position data value
pw?	- send power
rn?	- read current range
rn <float> (0.0 for auto)	- set the current range

FieldMaster GS

Help File (cont'd)

Hit any key to continue.

Valid commands: (spaces are significant)

q	- restart system
t <12 bit>	- write to contrast dac
tr <p/t>	- set trend mode pulse/time
tp <number>	- set trend number of points <200-2000>
tp?	- send trend number of points
tpa?	- send trend stats - average power
tpm?	- send trend stats - maximum power
tpl?	- send trend stats - minimum power
tpd?	- send trend stats - power standard deviation
tps?	- send trend stats - power 2 sigma stability
tea?	- send trend stats - average energy
tem?	- send trend stats - maximum energy
tel?	- send trend stats - minimum energy
ted?	- send trend stats - energy standard deviation
tes?	- send trend stats - energy 2 sigma stability
tfa?	- send trend stats - average frequency
tfm?	- send trend stats - maximum frequency
tfl?	- send trend stats - minimum frequency
tfd?	- send trend stats - frequency standard deviation
tfs?	- send trend stats - frequency 2 sigma stability
ti?	- send trend interval
tf? <number>	- send trend frequency at (0-number of points
ti <"mm:ss.s">	- set trend interval
ts	- start trend (send ts 2 times)
te	- end trend

FieldMaster GS

Help File (cont'd)

td <"hh:mm:ss">	- set trend duration
td?	- send trend duration
tv? <number>	- send trend data point (0-number of points)
v	- show Software version number
wv <wavelength m>	- set wavelength in meters
wv	- read wavelength in meters

Warranty

The seller warrants to the original Buyer each item manufactured by it to be free from defects in material and workmanship for a period of time and under such conditions as specified in the Seller's warranty for the individual product, or for twelve (12) months from delivery if a warranty for the individual product is not specified. Major sub-systems manufactured by other firms but integrated into the Seller's systems are covered by the original Manufacturer's warranty. The Seller's liability under valid warranty claims is limited to repair or replacement at the Seller's plant or the Buyer's location, all at the option of the Seller.

THE FOREGOING WARRANTY IS EXCLUSIVE AND IN LIEU OF ALL OTHER WARRANTIES, WHETHER WRITTEN, ORAL OR IMPLIED AND SHALL BE THE BUYER'S SOLE REMEDY AND THE SELLER'S SOLE LIABILITY ON CONTRACT OR WARRANTY OR OTHERWISE FOR THE PRODUCT. THE SELLER DISCLAIMS ANY IMPLIED WARRANTY OR MERCHANTABILITY OR FITNESS FOR PURPOSE.

All claims under warranty must be made promptly after occurrence of circumstances giving rise thereto, must be received within the applicable warranty period by the Seller, and shall be subject to the terms and conditions stated herein. Such claims should include the product serial number, the date of shipment, and a full description of the circumstances giving rise to the claim. Before any products are returned for repair and/or adjustment, authorization for the return and instructions as to how and where these Products should be shipped must be obtained from the Seller. Any product returned to the Seller for examination and/or warranty repair shall be sent prepaid via the means of transportation indicated as acceptable by the Seller. The Seller reserves the right to reject any warranty claim on any item that has been shipped by non-acceptable means of transportation. When any product is returned for examination and inspection, or for any other reason, the Buyer and its shipping agency shall be responsible for all damage resulting from improper packing or handling, and for loss in transit, notwithstanding any defect of non-conformity in the Product. In all cases, the Seller has sole responsibility for determining the cause and nature of failure, and the Seller's determination with regard thereto shall be final.

If it is found the Seller's Product has been returned without cause and is still serviceable, the Buyer will be notified and the Product returned at the Buyer's expense. A charge for testing and examination may, in the Seller's sole discretion, be made on products so returned.

Sales & Service Information

Thirty years of innovation

Coherent has been the world leader in the manufacture of lasers, and the instruments to measure them, for over thirty years. Coherent offers complete solutions for laser characterization, process control, and system design.

You may contact your local representative or Coherent for further information regarding these items. Call and ask for one of our customer care specialists. Purchase orders may be placed by phone, fax or mail.

United States

2303 Lindbergh Street
Auburn, CA 95602
Sales Tel: 1-800-343-4912
Sales Fax: 530-889-5366
Service Tel: (530) 888-5062
Service Fax: (530) 889-5262

United Kingdom

15 Greycaine Road
Watford, Herts WD24 7GW
England
Free Phone: 0800 515801
Tel: +44 (0) 1923 206900
Fax: +44 (0) 1923 244461

Germany

Dieselstraße 5b
D-64807
Dieburg
Germany
Tel: +49-6071-968-0
Fax: +49-6071-968-499

France

Domaine Technologique
de Saclay
Bâtiment AZUR
4, rue René Razel
91892 Orsay Cedex
France
Tel: +33-1-60 19 40 40
Fax: +33-1-60 19 40 00

Japan

Toyo MK Building
7-2-14 Toyo
Koto-ku
Tokyo 135
Japan
Tel: +81 (0) 3 5635 8680
Fax: +81 (0) 3 5635 8681

www.CoherentInc.com

United States
2303 Lindbergh Street
Auburn, CA 95602
U.S.A.
Toll Free: 1-800-343-4912
Tel: 530-889-5365
Fax: 530-889-5366

United Kingdom
15 Greycaine Road
Watford, Herts WD24 7GW
England
Free Phone: 0800 515801
Tel: +44 (0) 1923 206900
Fax: +44 (0) 1923 244461

Germany
Dieselstraße 5b
D-64807
Dieburg
Germany
Tel: +49-6071-968-0
Fax: +49-6071-968-499

France
Domaine Technologique de Saclay
Bâtiment AZUR
4, rue René Razel.
91892 Orsay Cedex
France
Tel: +33-1-60 19 40 40
Fax: +33-1-60 19 40 00

Japan
Toyo MK Building
7-2-14 Toyo
Koto-ku
Tokyo 135
Japan
Tel: +81 (0) 3 5635 8680
Fax: +81 (0) 3 5635 8681

Artisan Technology Group is an independent supplier of quality pre-owned equipment

Gold-standard solutions

Extend the life of your critical industrial, commercial, and military systems with our superior service and support.

We buy equipment

Planning to upgrade your current equipment? Have surplus equipment taking up shelf space? We'll give it a new home.

Learn more!

Visit us at artisanng.com for more info on price quotes, drivers, technical specifications, manuals, and documentation.

Artisan Scientific Corporation dba Artisan Technology Group is not an affiliate, representative, or authorized distributor for any manufacturer listed herein.

We're here to make your life easier. How can we help you today?

(217) 352-9330 | sales@artisanng.com | artisanng.com

